

3-5 S-band Frequency Converter

HASHIMOTO Yukio

We developed the S-band converter for engineering test satellite VIII (ETS-VIII). The S-band converter consists of an IF-band switch network, frequency converters, and an S-band switch network. The Ka-band RF section and two on-board switches were connected to an S-band RF section by an IF-band switch network. We adjusted the TX / RX frequency conversion function, signal route and the transmission / received signal levels. We refurbished engineering model frequency converters into flight models. The IF-band and S-band switches were used from the initial development stages. We maintained the specification performance after the engineering model tests.

Keywords

Mobile satellite communication, ETS-VIII, S-band

1 Introduction

The Engineering Test Satellite VIII (ETS-VIII) has two feeder-links consisting of radio circuits in the Ka-band (dedicated for the base station) and three service-links consisting of radio circuits in the S-band (dedicated for mobile users). The satellite carries both an on-board processor (OBP) for voice communication and a packet switch (PKT), which are connected to transmitter/receivers for feeder links and service links in the 140-MHz IF (Intermediate Frequency) band. An S-band converter functions to switch between devices to be connected, adjust signal level, and more, serving in part as a transmitter/receiver for the service link; this device is important in executing the circuit settings necessary for experiments in ETS-VIII.

The configuration, functions, and performance of the S-band converter are described below.

2 Overall configuration

The main specifications of the S-band converter are shown in Table 1. The overall con-

figuration is shown in Fig.1 [1][2]. The S-band converter is composed of an IF-band switch network, S-band frequency converters, and an S-band switch network, and connects Ka-band

Table 1 Main specifications of S-band converter

Temperature	-20 to +50 degrees C
Power Monitor Sensitivity	1 bit: 20 mV or over/1dB @ -10 to +14 dBm
Nominal Gain	S-TX: 34 dB, S-RX: 65 dB
Gain Control	-16 to +15 dB, less than 2dB / step, (nominal 1dB/step)
Local Frequency	RX: 2517.5 MHz, TX: 2362.5 MHz,
Frequency Ailment	less than +/- 1E-7
Frequency Stability	less than +/- 2E-7 / 20 degrees C
Frequency Control	more than +/- 1.2E-6 / 64 steps, (less than +/- 1E-7 / step)
Oscillator warm up time	less than 2 hours
Phase Noise	less than -45 * -10 log(Δf) dBc / Hz
Maximum Input level	TX: +10 dBm, RX: -50 dBm
Maximum Output level	TX: +25 dBm, RX: +10 dBm (saturated)
Supply Power	28.5 W
Weight	16.5 kg

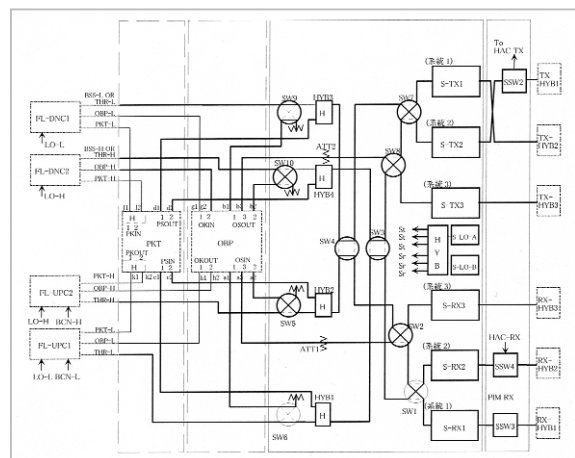

Fig. 1 Block diagram of S-band converter

feeder link communications equipments and satellite on-board switches to an S-band feed system. The IF-band switch network connects two feeder links, the OBP, the PKT, and three service links, and has a signal-routing function to establish the signal routes required for experimentation. The S-band frequency converters perform frequency conversion between the S-band and the IF-band, acting partially as transmitters/receivers for service-link operations. The S-band switch network connects an S-band RF section to a PIM (passive inter-modulation) measurement system and to a HAC (High Accuracy Clock) system transmitter/receiver.

Two sets of transmitted-frequency/received-frequency converters were manufactured as EMs (Engineering Models), and have since been refurbished as FMs (Flight Models) following various EM tests. One of these converters (a transmitted-frequency/received-frequency pair) were also manufactured as FMs, reflecting the results of the EM tests. FMs for the IF-band switch network and the S-band switch network were employed both in EM testing and thereafter.

Several operational modes are being considered for the ETS-VIII; each of these modes features a different device configuration designed based on experimental results. These operational modes include the broadcast/through mode (incorporating bent-pipe relaying); the S-band turn-around mode; and the PKT and OBP modes, each of which uses different on-board switches. When setting the switch network, one signal route is available in broadcast mode, two routes are available both in through mode and in packet switch mode, and two feeder links and three service links are available in OBP mode. Moreover, two routes are available in the S-band turn-around mode, which enables bi-directional communication between beams.

Although each of the transmission-frequency/received-frequency converters offers the same characteristics, the S-TX3 and S-RX3 signals cannot be converted to those of other converters due to restrictions on the IF-

band switch network. The service links are set such that two routes are active systems and one route is a redundant system, but these links are configured to enable the three routes to be used simultaneously in OBP mode operations, experiments on interference between beams, and the like.

The three transmission frequency converters correspond to the three beams formed by the beam-forming networks (BFNs) of the S-band feed system. Similarly, the received frequency converters correspond to the signals of the three beams output from the BFNs. The transmission-frequency/received-frequency converters have built-in variable attenuators enabling adjustment of the respective signal levels.

3 IF-band switch network

The IF-band switch network is composed of ten double-pole double-throw switches (SW1 to SW10), four hybrids (HYB1 to HYB4), two fixed attenuators, and coaxial cables, and connects two input/output ports of the feeder-link communications equipment, two input/output ports of the packet switch, and three input/output ports of the OBP to three S-band frequency converters. Switch devices and coaxial cables are designed such that the degree of freedom in connection is increased without impairing reliability. Switching is performed between the feeder link and the OBP by the SWs. Connection to and from the PKT is made through hybrids. Since input/output of the third input/output port of the OBP does not pass through hybrids, fixed attenuators (3.5 dB) are inserted at this port in order to even out the signal loss. With the routing of the IF-band switch network illustrated in Fig.1, one signal channel can be used for the broadcast mode, one for the through mode, one for the PKT mode, and one for the OBP mode; this routing is defined as the standard connection setting, as it enables a certain number of experiments to be performed without operating switches. Table 2 shows the signal loss for a typical route.

Table 2 Example of loss of IF-band switch network

Route	Loss (dB)
OBP1 output-S-TX2 output (SW9-HYB3-SW4-SW7)	28.22 @2502.5 MHz
OBP2 output-S-TX1 output (SW10-HYB4-SW3-SW8-SW7)	29.33 @2502.5 MHz
OBP3 output-S-TX3 output (SW8)	29.67 @2502.5 MHz
S-RX2 input-OBP1 output (SW1-SW3-HYB1-SW6)	59.08 @2656.75 MHz
S-RX1 input-OBP2 output (SW1-SW2-SW4-HYB2-SW5)	58.88 @2656.75 MHz
S-RX3 input-OBP3 output (SW2)	59.26 @2656.75 MHz
PKT1 output-S-TX2 output (HYB3-SW4-SW7)	28.58 @2502.5 MHz
PKT2 output-S-TX1 output (HYB4-SW3-SW8-SW7)	28.35 @2502.5 MHz
S-RX2 input-PKT1 input (SW1-SW3-HYB1)	59.85 @2656.75 MHz
S-RX1 input-PKT2 input (SW1-SW2-SW4-HYB2)	59.81 @2656.75 MHz
BSS/THR-L output-S-TX2 output (SW9-HYB3-SW4-SW7)	28.81 @2656.75 MHz
BSS/THR-H output-S-TX1 output (SW10-HYB4-SW3-SW8-SW7)	28.55 @2656.75 MHz
S-RX2 input-THR-L output (SW1-SW3-HYB1-SW6)	59.85 @2656.75 MHz
S-RX1 input-THR-H output (SW1-SW2-SW4-HYB2-SW5)	59.73 @2656.75 MHz
S-RX1 input-S-TX1 output (SW1-SW2-SW4-SW7)	95.23 @2657.5 MHz
S-RX2 input-S-TX2 output (SW1-SW3-SW8-SW7)	95.60 @2657.5 MHz
S-RX2 input-OBP3 input (SW1-SW2)	59.26 @2656.75 MHz
OBP3 output-S-TX2 output (SW8-SW7)	29.36 @2502.5 MHz

4 Frequency converter

4.1 Transmission frequency converter

The configuration of the transmission frequency converter is shown in Fig.2. The frequency converter has a level-adjustment function (which changes the signal level in response to a command), in addition to a frequency-conversion function. Fig.3 shows the characteristics of the gain-adjustment function.

Although in the ETS-VIII the transmission power of each solid state power amplifier

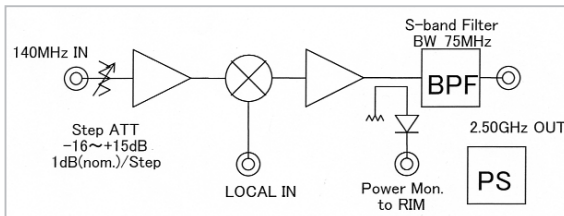

Fig.2 Block diagram of transmission-frequency converter

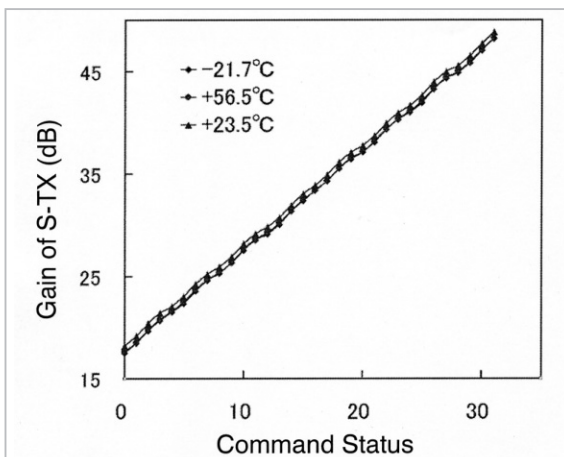

Fig.3 Characteristics of gain-adjustment function

(SSPA) in the S-band can be determined from the telemetry of the SSPA, the transmission power of each beam within a given SSPA cannot be known, as the beam signals are amplified in common. The transmission power of each beam must therefore be calculated from the output power telemetry of the transmission-frequency converter corresponding to the given beam. Fig.4 shows the correlation between output power of the transmission-frequency converter and the telemetry voltage.

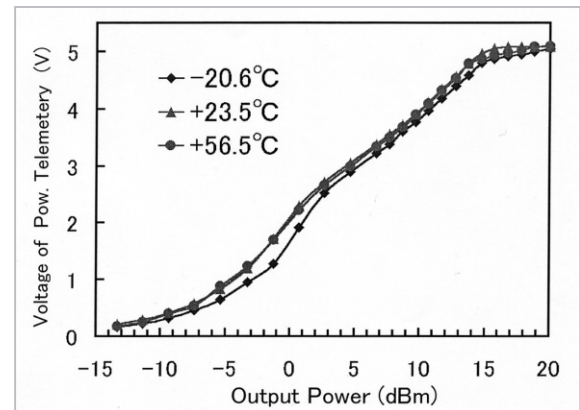

Fig.4 Telemetry voltage versus output power

4.2 Received-frequency converter

The configuration of the received-frequency converter is shown in Fig.5. The frequency converter has a level-adjustment function (which changes the signal level in response to a command), in addition to a frequency-conversion function. In order to avoid interference from neighboring satellites, the output stage of the 140-MHz IF band is equipped with a SAW filter. Fig.6 shows amplitude versus frequency characteristics. Note that since the output of the RX-3 features a lower saturation level than other RXs, particular care must be taken when using RX-3.

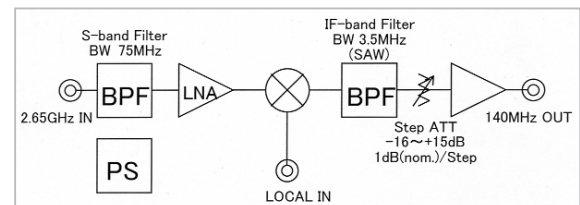

Fig.5 Block diagram of received-frequency converter

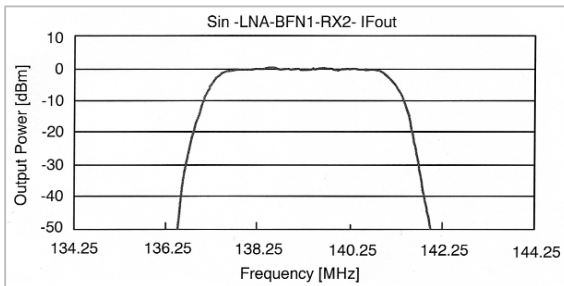

Fig.6 Amplitude versus frequency characteristics of S-band receiving system

4.3 Local signal generator

The local signal generator in fact consists of two signal generators: a primary signal generator and a redundant signal generator. Each generator creates two signals of differing frequencies: a local signal for transmission and a local signal for reception. The local signals are distributed to the frequency converters through hybrids, to maximize signal reliability. Selection between the primary system and the redundant system is effected through selection of the device to be activated. A frequency variation of $1 \times 10E-7$ or more is expected during actual orbital satellite missions; nevertheless, the signal generators are configured to be able to change output frequencies in steps of $1 \times 10E-7$ or less. Fig.7 shows local signal frequency deviation versus command status.

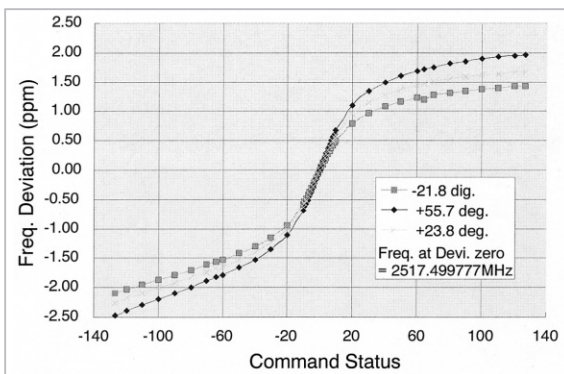

Fig.7 Local signal frequency deviation versus command status

5 S-band switching network

The S-band switching network has one switch for the transmitting system and two switches for the receiving system. The S-band transmitting unit is equipped with one feeder element for reception to perform PIM (passive intermodulation) measurement of the S-band antenna system. One of the switches in the receiving system functions to switch the system to the S-band. A transmitting system/receiving system switch pair switches the service-link transmitter/receiver to the backup HAC system transmitter/receiver in the case of failed deployment of the S-band large deployable reflector.

6 Concluding remarks

The S-band converter has indispensable functions, allowing for setting of the signal route in the ETS-VIII and for the adjustment of signal level. Several elements of this critical converter had to be developed from scratch. As a result, SWs and other components were developed directly for the FM, while the EM of the frequency converter was refurbished through slight modifications for use in the FM.

Following individual testing and to combined testing with an S-band transponder, the S-band converter has been installed on the ETS-VIII at the National Space Development Agency of Japan (NASDA, presently the JAXA: Japan Aerospace Exploration Agency); various additional tests are now underway as part of overall satellite testing [3]. The S-band converter has presented no major difficulties either in EM testing or thereafter, maintaining the desired performance throughout.

This equipment was developed by the Advanced Space Communication Research Laboratory (ASC) and was subsequently transferred to the CRL following completion of the former organization's research activities.

References

- 1 F. Kawasaki, et al, "An Onboard Transponder System for S-band Mobile Communications and Broadcasting System", 21st ISTS, ISTS 98-h-03.
- 2 F. Kawasaki, et al, "Design of ETS-VIII On-Board Transponder", IEICE Society Conference, B-3-14, Sep. 1998. (in Japanese)
- 3 S. Kozono, et al, "Mobile Satellite Communications System for the ETS-VIII—Test of the Electrical Performance", IEICE General Conference, B-3-12, Mar. 2003. (in Japanese)



HASHIMOTO Yukio

*Senior Researcher, Broadband Satellite
Network Group, Wireless Communica-
tions Division*

Satellite Communication

